

Introduction

1. Introduction

Congratulations on an excellent buy - you have purchased a unique plasma system, the MULTIPLAZ-3500!

1.1 Compliance

- System is compliant with the IEC/EN 60974-1, 60974-7 standards requirements

1.2 Manufacturer's Undertakings

Warranty: 24 months from date of sale provided the seal is undamaged, there is no exterior damage and storage, transportation and operating requirements are complied with. Repairs under warranty are performed by the authorized dealer on presentation of the warranty. Repairs under warranty will be performed if the system has been properly maintained.

Caution!

- The useful life of the system is 10 years if the operating and maintenance procedures are followed.

1.3 Storage, Transportation, and Operating Conditions.

Prior to putting into operation, the system should be stored indoors in manufacturer's packaging at temperatures of between -50C and +50C and a relative humidity of 98% at 25C. After putting into operation, the system shall be stored indoors at temperatures of above 0C. The system may be stored at -50C provided the torches are dry.

Prior to putting into operation, the system must be transported in original packaging at temperatures of between -50C and +50C, a relative humidity of up to 98% at 25C, and an atmospheric pressure in excess of 12 kPa. The system must be protected from direct effects of precipitation.

The system should be operated indoors or in an open shed at an ambient temperature of between -10C and +40C, an average monthly relative humidity of up to 90% at +20C, up to 80% at +25C, and up to 60% at +40C out of direct sunlight, sand or dust (especially conductive dust)

The system may be operated at temperatures down to -30C when prior to operation the system has been indoors at above-freezing temperature for at least three hours.

1.4 System Application

The Multiplaz-3500 portable system is designed for manual plasma cutting, welding, soldering, braze welding, and brazing (joining of dissimilar metals) of ferrous and non-ferrous metals including alloyed and unalloyed steels, cast iron, copper and copper-base metals, stainless steel, aluminum and aluminum alloys. The system can be used to perform separation plasma cutting of

various nonconductive nonflammable materials, including cement, concrete, brick, haydite aggregate, quartz glass, etc.

The device works from the household electric system, using for welding and brazing a water solution of ethyl alcohol (ethanol), and for cutting just water. The device can work on any water, and quality of welding and cutting does not depend on quality of water. However, to increase of service life and simplification of maintenance service, it is better to use water with smaller amount of minerals, the best is distilled water.

Caution!

The circuit breaker in the wall receptacle circuit should be rated for at least 25 A for 110V and at least 16A for 220V.

1.5 Specifications

Electrical Supply, V (single phase).....	100-253
Supply Frequency, Hz.....	50-60
Maximum Power Requirement, KWt	for network voltage 220V.....3.5
	for network voltage 110V.....2.0
Power Supply Weight, kg.....	8
Torch Weight (dry),kg.....	0,9
Liquid Consumption, liters/hour.....	0,25
Idle Voltage, V (not to exceed).....	68
Torch Steam Pressure, bar.....	0,4-1,2
Duty Cycle, %.....	100
Power Supply Dimensions (l x h x w), mm.....	380 x 190 x 140
	(l x h x w), inch.....15,0 x 7,5 x 5,5
Torch Dimensions (l x h x w), mm.....	205 x 194 x 60
	(l x h x w), inch.....8,1 x 7,4 x 2,4
Power Cable Length, m.....	2
Torch Cable Length, m.....	2

1.6 What's included

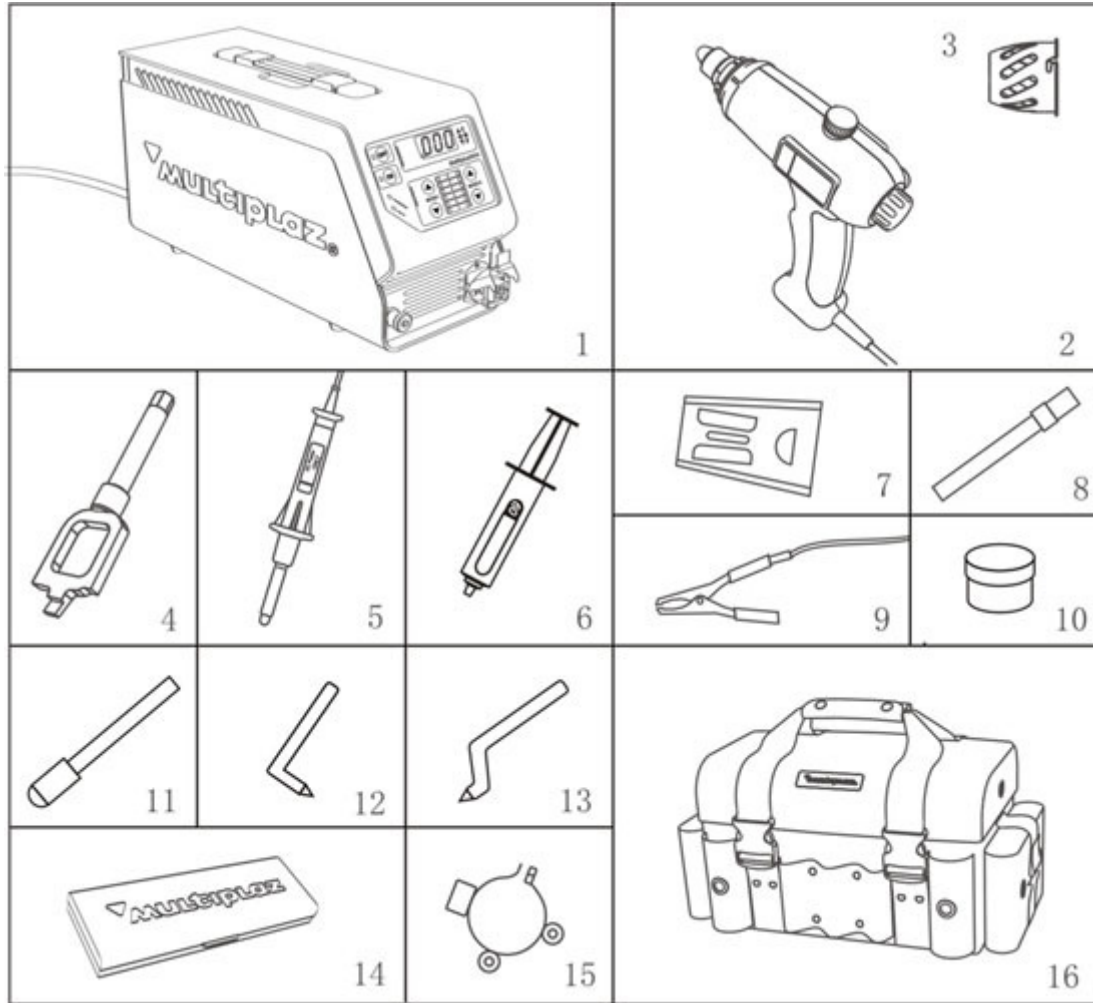

- 1. Power Supply.....1 pcs.
- 2. Torch.....2 pcs.
- 3. Protective Tip.....1 pcs.
- 4. Combination Wrench.....1 pcs.
- 5. Filler Holder.....1 pcs.
- 6. Syringe.....2 pcs.
- 7. Torch holder.....1 pcs.
- 8. Plunger.....1 pcs.
- 9. MODE II Wire with Clamp.....1 pcs.
- 10. Specialized Graphite Lubricant.....1 pcs.
- 11. Ball Support.....1 pcs.
- 12. Support.....1 pcs.
- 13. Compass.....1 pcs.
- 14. Spare Parts Kit.....1 pcs.
- 15. Clamp Bracket.....1 pcs.
- 16. Case.....1 pcs.
- 17. Operating Manual.....1 pcs.
- 18. Service Certificate.....1 pcs.

Note: Design of some parts may be different from shown above.

Spare Parts Kit

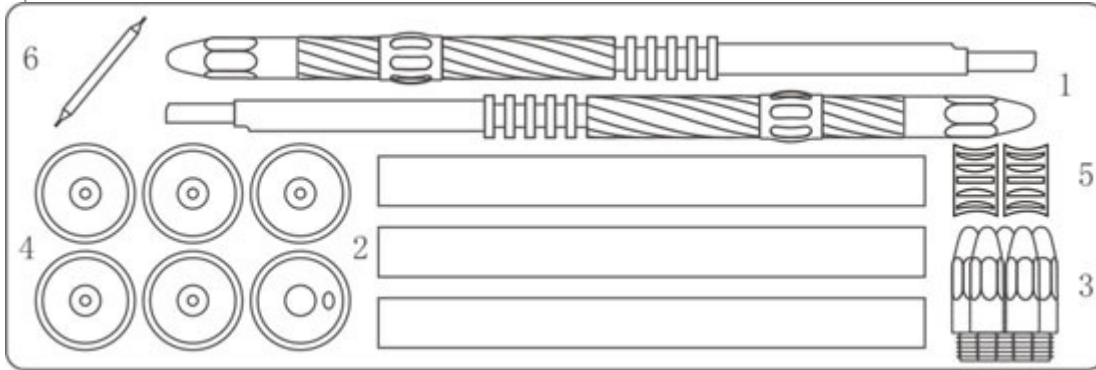

- 1. Cathode Assembly.....2 pcs
- 2. Quartz Tube.....3 pcs
- 3. Cathode.....5 pcs
- 4. Nozzle.....6 pcs
- 5. Spring.....2 pcs
- 6. Drill Bit 1.1 mm (0,043 inch).....1 pcs

Caution!

The manufacturer is not responsible for any damage caused to the system as a result of improper operating procedures listed in this manual or improper use of the system.

Safety

2. Safety

The manufacturer cannot be responsible for any damage resulting from improper, erroneous, or incorrect use. If safety precautions are not taken, the manufacturer will not be held responsible for the consequences.

Operate the system only as described in this manual.

The Multiplaz-3500 system safety is assured by design as well as manufacturing and operating procedures. Per specification, all systems are tested for power supply compliance with insulation and ground resistance requirements. Torches are also tested for insulation strength.

In addition, safety is assured by a grounding circuit included in system design. Per the design requirements, the grounding circuit has to be connected to an outside ground. The manufacturer is not responsible for any damage resulting from failure to connect ground.

The system design also includes a series of circuit breakers which disconnects the power supply output voltage under the following circumstances:

- short circuit in torch for 5 seconds;
- increase in torch or power supply temperature;
- broken sensor wire in gun;
- idle voltage at power supply output for over 5 seconds.

Since arc welding equipment is mostly designed for industrial applications, its electromagnetic compatibility (EMC) with electronic and electrical equipment should be taken into account under other circumstances as well because of interference fed back into the circuitry or generated by electromagnetic radiation. In the event of interference, the user should request a qualified specialist who might consult the manufacturer and modify grounding circuitry or install power filters, additional cable or system shielding, etc. to improve EMC.

The system is equipped with a slow blow fuse rated for 25A (fuse dimensions: diameter 6.3mm - length 32 mm, i.e. diameter 1/4 in - length 1 1/4 in) . Please contact your authorized dealer with any questions about the 25A fuse.

Additional system safety is provided by a limitation of 68 V imposed on idle voltage between torch nozzle and workpiece metal (unit housing) in the absence of a direct arc.

The illuminated green SELV indicator on power supply front panel is a signal that voltage between torch nozzle and workpiece does not exceed 68 V.

A protective tip is used to protect from electric shock resulting from contact with torch nozzle or cap when voltage on those components may exceed 68 V.

2.1 Safety Precautions for System and Workstation Equipment Setup

- Verify system integrity and completeness after packaging is removed and before system is connected. If there is concern regarding system health, do not use system and call a qualified dealer.
- Do not leave packaging (plastic bags, polystyrene foam, etc.) in areas accessible to children since it is a potential source of hazard.
- Prior to activating the system, verify that power circuitry voltage is the same as the rating on power supply housing and that the electrical outlet is designed for a current of at least 16 A for 220V. (For 110V - at least 20 A)
- Use grounded receptacles to connect the system (ground may be provided through grounding connector on rear of power supply).
- Do not connect the system to power if there is visible damage on its housing or power cable. Do not attempt to repair the power cable on your own. In the event of cable damage call qualified personnel. If needed, replace power cable using only certified cable made from H05RRF rubber and authorized by the manufacturer for this application or supplied with the system.
- On your own or using qualified personnel, assess possible EMC problems relative to other equipment around the work location, including areas outside the room with emphasis on cables, radio and TV equipment, computers, alarm and security systems, instrumentation, etc.
- Warn persons using hearing aids of possible interference from welding equipment.
- Use a power cord extension with a cross-section of at least 2.5 sq. mm (13 AWG) and a grounding wire resistance not exceeding 0.1 Ohm.
- Place power supply on a level, stable surface.
- Verify that the work location is not accessible to children.
- Equip work location with fire suppression equipment.
- Remove flammable materials from work location.
- Arrange for ventilation or air the room while operating the equipment.
- Arrange work location in such a manner as to preclude contact of molten metal, torch plume and hot air with power supply or power cable.
- Do not place power supply in close proximity of heating equipment, open flame or other sources of heat.
- Do not obstruct power supply vent holes.
- Use welder personal protective gear.
- Always power down and unplug the system if its is not being used, needs to be maintained, or if tooling needs to be installed.
- Store system in strict compliance with the storage requirements specified in Section 1.3

2.2. Operating Safety Precautions

It is prohibited:

- To activate or operate the system without having studied this manual.
- To use the system for any purpose other than welding, cutting, soldering, brazing, or braze welding.
- To modify or disassemble the system in ways other than specified in this manual.
- To allow access to or use of system by children, persons with health issues, or with pacemakers without first consulting a physician.
- To leave active system unattended.
- To violate the requirements of safety system standards.

- To connect or attach any accessories to power supply or torch other than those recommended by the manufacturer and listed in this manual (other accessories may cause damage to the system or create a hazard for the user).
- To connect any torch other than the Multiplaz-3500 to the Multiplaz-3500 power supply.
- To connect the Multiplaz-3500 torch to any power supplies other than Multiplaz-3500.
- To connect torch to any outside sources of process fluid (gas bottles, compressors, fluid tanks etc.) which are not approved by the manufacturer.
- To fill the torch with fluids other than those specified by this manual (water and ethanol/water mixture).
- To place power supply or operational torch on surfaces with a grade in excess of 10° without using fasteners to protect them from overturning.
- To use torch with the front panel SELV indicator off without installing a protective tip (i. e., in modes requiring voltages in excess of 68 V at torch cap and nozzle).
- To operate with power supply housing ungrounded.
- To operate the system without wearing special protective dark goggles while operating in MODE I or without a welder's mask while operating in MODE II. The recommended light state is 4 DIN for MODE I and 5.5 DIN for MODE II.
- To operate the system on floor that is metal or damp without using an insulating floor mat.
- To operate the system while wearing wet shoes and/or with wet feet.
- To touch power supply with wet or damp hands.
- To use torch on recently painted structures.
- To operate the system while wearing clothing stained with flammable substances.
- To use the system on items filled with hazardous substances, water, ice or items under pressure or voltage.
- To use painted, zinc-plated items, or fluxes in an unventilated room.
- To operate in dusty rooms or rooms where metals are being worked using abrasion.
- To use the system to thaw pipes.
- To touch hot system components.
- To move power supply during operations.
- To pull the system by the power cable or coil the power cable around the system.
- To wipe power supply down with a damp cloth
- To try and repair the system or torch by yourself except as specified in Sections 6 and 7. Contact a qualified dealer for any repair-related issues.

Specifications and Operating Principle

3. Specification and Operating Principle

The Multiplaz-3500 portable plasma system is a source of low-temperature plasma obtained by heating to ionization temperature vapors of a process fluid placed in the torch prior to operations. The system is designed for continuous operation (duty cycle of 100%). The system has a plasma torch and a power supply.

3.1 Torch

The torch is a primary system component which generates low-temperature plasma. The torch is made up of the following components:

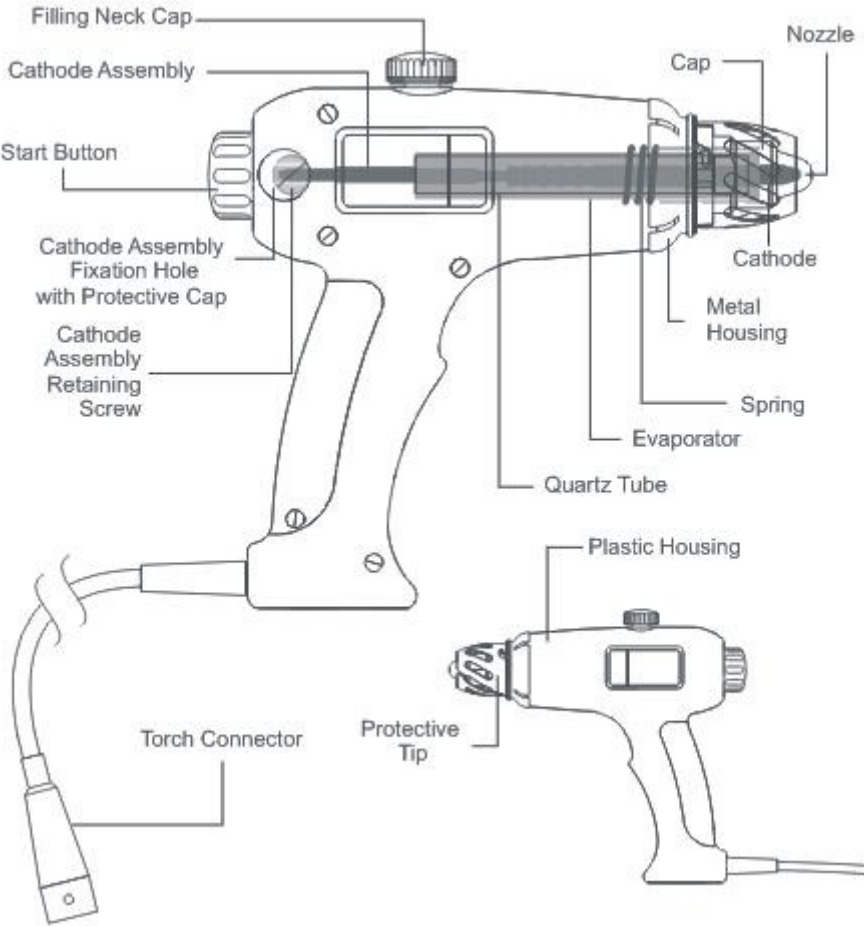

3.2 Torch Operating Principle

Once the torch is filled with the proper fluid, the power supply is connected, and voltage is applied to the cathode (the ON button is pressed), the operator can cause the torch to produce an arc by pressing the start button briefly. This results in the cathode shorting to the torch nozzle. As the start button is released, an electric arc is produced between the cathode and nozzle. Arc energy heats the nozzle, which in turn heats the evaporator, which causes the fluid to heat and turn into steam. Steam flows toward the nozzle outlet under internal pressure (0.4-1.2 bar). Escaping from

the nozzle, steam compresses the electric arc. Arc compression increases arc temperature. Compressed electric arc heats the steam to ionization temperature.

The system has two modes of operation.

MODE I is the indirect arc mode. An electric arc is produced between cathode and nozzle. The plasma jet is the only vehicle that transfers energy to the workpiece material.

MODE II is the direct arc mode. The conductive workpiece is part of the cutting (welding) circuit, and the electric arc is produced between the workpiece and the cathode inside the plasma jet. This causes a significant increase in the amount of thermal energy transferred to the workpiece.

The device includes two torches, which are structurally identical. One with a green label is initially equipped for cutting and the torch with the red label for welding. These torches are interchangeable by changing the nozzle, by adjusting the cathode assembly (see Section 6.6.2), and by replacing the working liquid (water or water/ethanol mixture). We recommend using each torch in accordance to its respective color-coded labels.

3.3. Power Supply

Inverter power supply with forced air cooling acts as a current conditioner and has a steeply sloping output characteristic. Reliable current conditioning for plasma torch electrical arc is performed for a wide range of output voltages applied to the torch.

A power cable 3 x 2.5 mm² (3 wires of 13 AWG) is used to connect the power supply to outside power (grounding wire is green-yellow in color).

The top of the unit is equipped with a carrying handle.

The power supply comprises:

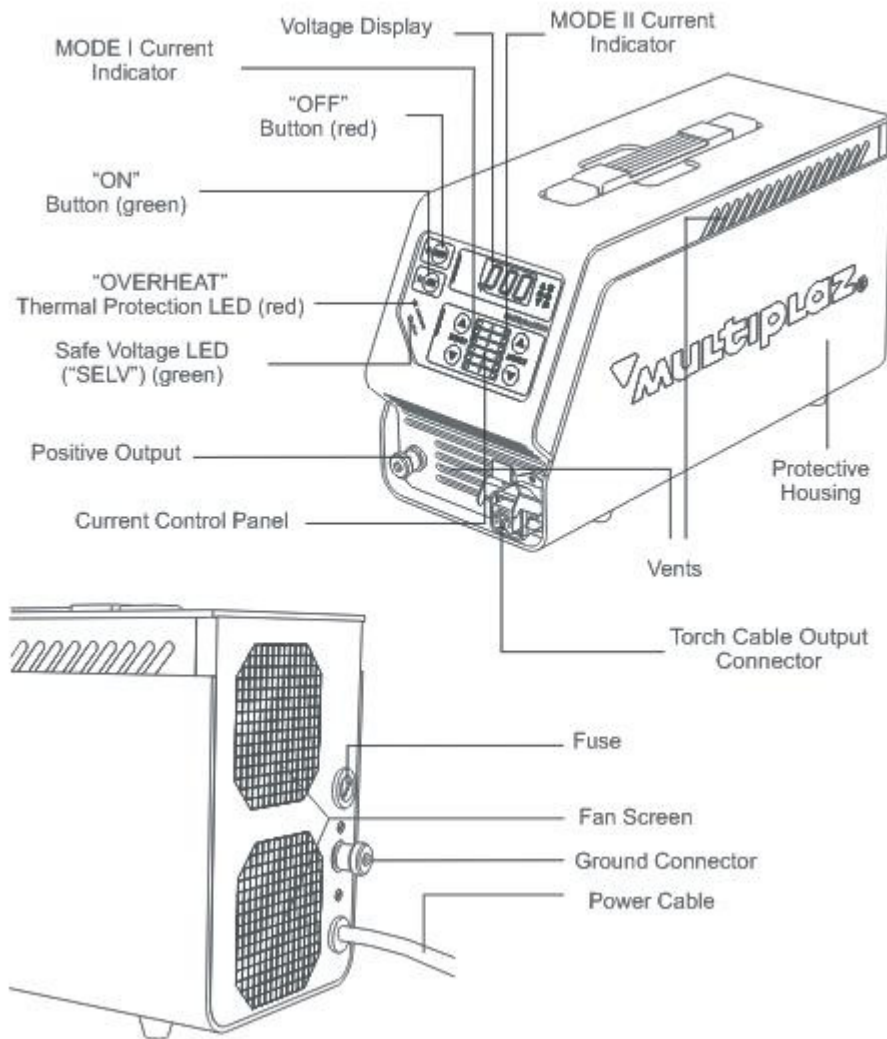

Caution!

Replacement of a plug should be made only by authorized personnel observing the following requirements:

- The plug and the socket should be rated for a working current not less than 20A for standard voltages of 100, 110, 120 V and 16A for standard voltages of 208, 220, 230, 240 V.
- When connecting wire, observe the following conformity between contacts of the plug and cable wires:
 - Black (brown) for phase contact
 - White (blue or dark blue) for neutral contact
 - Yellow (green or yellow-green) for ground contact

3.4 Controls

Operating mode is selected by adjusting current and voltage values.

To increase or decrease current use the 5or6buttons respectively on the current control panel.

Current value is determined by the setting on a backlit indicator: for MODE I in the left column; for MODE II in the right column (see Table below).

Backlit Indicator Position	1	2	3	4	5	6
Current Value, A	3	4	5	6	7.5	9.5

Caution!

- For 110 V power supply, only positions 1 through 4 are available. Positions 5-6 will not work.

To select direct arc mode (MODE II), press the right 5 button on the current control panel.

Current values in MODE II may be adjusted between the value set in MODE I and the maximum value of 9.5 A in position 6.

To deactivate direct arc mode (MODE II), press the right 6 button until the indicator in the right column is extinguished.

Voltage may be adjusted by rotating the torch start button.

Rotate clockwise to increase voltage; rotate counterclockwise to reduce voltage. The voltage value in MODE I is shown on the voltage display (see Figure). In MODE II, the voltage display shows "Arc".



Cutting

4. Cutting - Use distilled water

Study the Safety section and comply with its requirements.

4.1 Connection of Power Supply

- Connect power supply power cable to wall receptacle.
- Verify that voltage display and "OFF" LED are illuminated.
- Verify that fan is on.

Caution!

Voltage display may show a value of up to 5 volts if the "OFF" LED is illuminated.

4.2 Torch Connection to Power Supply

- Take cutting torch with green mark.
- Make certain that power supply "OFF" LED is illuminated.
- Connect torch cable connector to power supply output connector (see Figure).
- Secure connection with connector latch.



4.3 Power Supply Setup for Torch Start

- Connect MODE II cable with clamp to positive output on power supply front panel (see Figure).
- Press the left 5 or 6 buttons step-by-step to select position 4 of MODE I current indicator.

4.4 Torch Setup and Servicing.

- Cutting requires nozzle of diameter 1.1-1.3 mm, i.e. 0,043-0,051 inches (see spare parts kit). To replace nozzle follow Section 6.1, Steps 1 - 3 and Section 6.6, Steps 8 - 9.
- Rotate torch start button to set it's free movement to 2-3 mm (0.08-0.12 inches).
- If it is not possible to set free movement to 2-3 mm (0.08-0.12 inches), disassemble torch (see Section 6.1, Steps 1-5, 8-9) and adjust cathode holder position (see Section 6.6, Steps 1-3, 6-9).
- Take syringe and fill it with water (see 'What's included').
- Open the filling neck cap.
- Insert the syringe into filling neck hole and, while pressing the piston, fill until water starts to drip from the nozzle (see figure)
- After filling, close the filling neck cap tightly and wipe torch body

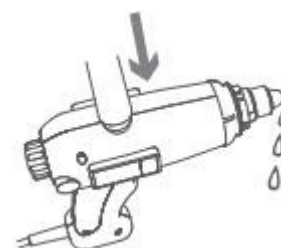

dry.

- Place torch on torch holder (see 'What's included').

Caution!

- Fill torch immediately prior to operations.
- While refueling, hold the torch with filling hole up and keep the nozzle level higher than the filling hole. .
- Starting unfilled torch result damage.



4.5 Torch Start

- Make certain that power supply "OFF" LED is illuminated.
- Depress and release "ON" button on power supply. Make certain that "ON" LED is on (voltage reading will jump briefly to 200-350 V) (see figure)

- Within 5 seconds after pressing "ON" button, fully depress start button (when cathode comes into contact with nozzle, voltage will drop to 0 - 5 V), and release it slowly (voltage in initialized arc is between 20 and 80 V).
- Several seconds later, a jet is supposed to appear from torch nozzle, while voltage will increase to 80 -160 V.
- Set operating voltage to 190 V by turning start button clockwise

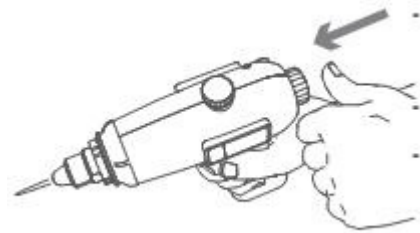

Caution!

- If arc fails to form (display reading remains at 200 - 350 V), press start button again within 5 seconds.
- If you fail to press the start button within the specified time, display reading will fall to 000 V and "OFF" LED will illuminate. If that were to happen, repeat start procedure (press "ON" button and press start button).
- If a jet fails to form within 8 to 10 seconds or an arc cannot be started, deactivate torch as specified in Sections 4.7, 4.9, identify and troubleshoot failure (see Section 7).

It is prohibited!

- to look inside nozzle to check for jet. It is dangerous!

4.6 Cutting Procedure

4.6.1 MODE I Cutting

MODE I cutting produces the narrowest cut. Cut at a constant rate. Maintain a clearance of between 1 and 3 mm (between 0.04 and 0,12 inches) between nozzle and workpiece (nozzle contact to workpiece is allowed). To achieve maximum cutting rate, use left 5 button to set current indicator on MODE I panel to position 6 (particulars on selecting current settings are given in Section 7.4) and turn start button clockwise to set voltage to 210 - 220 V (for 110 V power supply, set current indicator to position 4 and set voltage to 220 - 230 V).

4.6.2 MODE II Cutting

MODE II cutting is only used for conductive materials. MODE II cutting produces maximum rate and cut depth. This mode does not allow contact between nozzle and workpiece being cut.

- Connect MODE II wire with clamp to workpiece being cut (see figure).

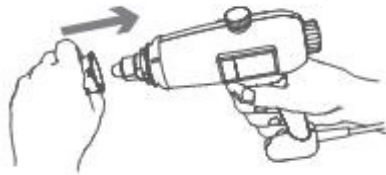

- Attach protective tip and turn until locked (see figure).
- Fill and start torch (see Sections 4.4,4.5)

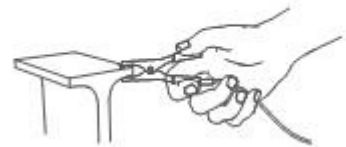

- Set current indicator MODE I to position 6 by pressing left 5button on panel (for 110 V power supply - position 4). Activate MODE II by pressing right 5button on panel.

- Turn start button to select a voltage of 210-220 V (for 110 V power supply - select a voltage of 220-230 V).

- Put on welder's mask (light shade of 5.5 DIN)
- Place nozzle with energized jet 1.2 - 2.0 mm (0,05-0,08 inches) from workpiece.
- Be sure that the electric arc has jumped to the workpiece.
- While cutting, hold torch at a right angle to workpiece surface (see figure).
- Hold electric arc on workpiece being cut for the entire time.
- Monitor evacuation of molten metal.
- To produce a straight cut, use devices from "What's included".

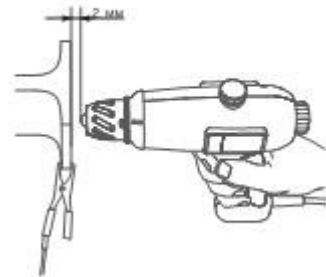

For further information on cutting process, refer to "Process Attachment"

Caution!

When operating in MODE I or MODE II:

- If the jet should become extinguished inadvertently, fully press and immediately but slowly release the torch start button within 5 seconds as for a nominal start to re-establish jet.
- When torch runs out of water, jet becomes elongated (or extinguished), and voltage reading drops. If this were to happen, shut torch down manually before it shuts down automatically from overheating.
- If torch runs dry, it shuts down automatically, and OVERHEAT LED of power supply is illuminated. To proceed with operation, perform steps in Section 4.8 and restart torch.

- Remove any molten splatter accumulated on nozzle by touching nozzle lightly with file or metal brush.
- Do not leave operating torch unattended.
- Do not allow unprotected areas of your body to come into contact with hot torch surfaces.
- When operating in MODE II do not allow conductive items to come into contact with nozzle or cap unless secured in filler holder.
- Do not remove filling neck cap while torch is operational.

4.7 Torch shutdown

- Press "OFF" button on power supply (see Figure)
- Verify that power supply "OFF" LED is illuminated.
- Cool torch by dipping nozzle in 3-5 cm (1-2 inches) of WATER for a several seconds until sizzling sound stops or keep it dipped for 2-3 minutes to fill the torch automatically (see 4.8.2).



Caution!

- Shut down and cool torch if nozzle turns red or jet turns green for a long time (see Sections 7.11, 7.12).



Caution!

If you want to shut torch off in case of emergency, press and hold start button 6-8 seconds.

4.8 Refilling Torch

Torch may be refilled in two ways

4.8.1 Forced refilling

- Fill the torch as written in Section 4.4

4.8.2 Automatic Filling

- Shut torch down per Section 4.7.
- Dip nozzle in 3-5 cm (1-2 inches) of water (free of sediment) for 2 - 3 minutes (see figure). This method can only be used immediately following torch shutdown because of the suction effect.
- Once filled, wipe torch dry.



4.9 After operation

- Press "OFF" button on power supply.
- Be sure "OFF" LED is illuminated.

- Disconnect torch cable from power supply output connector
- Disconnect power supply power cable from wall receptacle.
- Disconnect MODE II wire with clamp from power supply.

It is prohibited:

- to disconnect the torch cable connector with torch operational and/or "ON" LED illuminated. This results in connector burnout.

Welding, Brazing, Braze Welding, and Soldering

5. Welding, Brazing, Braze Welding, and Soldering

Study the Safety section and comply with its requirements.

5.1 Connection of Power Supply

- Connect power supply power cable to wall receptacle.
- Verify that voltage display and "OFF" LED are illuminated.
- Verify that fan is on.

Caution!

Voltage display may show a value of up to 5 volts if the "OFF" LED is illuminated.

5.2 Torch Connection to Power Supply

- Take welding torch with red mark.
- Make certain that power supply "OFF" LED is illuminated.
- Connect torch cable connector to power supply output connector (see figure).
- Secure connection with connector latch.



5.3 Power Supply Setup for Torch Start



- Connect MODE II wire with clamp to positive output on power supply front panel (see figure).

- Connect filler holder to grounding connector on power supply rear panel.

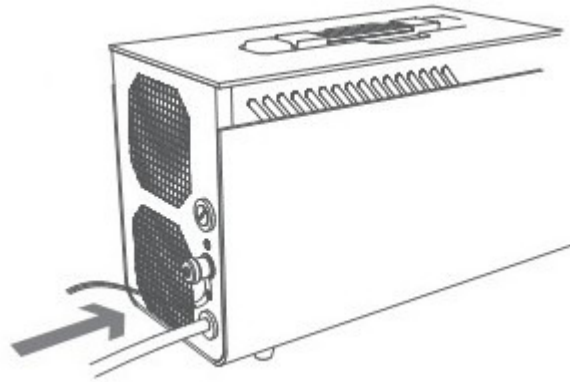

5.4 Torch Setup and Servicing.

- Welding requires nozzle of diameter 2.2-2.5 mm, i.e. 0,086-0,098 inches (see 'Spare Parts Kit'). To replace nozzle follow Section 6.1, Steps 1 - 3 and Section 6.6, Steps 8 - 9.

- Rotate torch start button to set it's free movement to 2-3 mm (i.e 0,08-0,12 inches).

- If it is not possible to set the free movement to 2-3 mm (i.e 0,08-0,12 inches), disassemble torch (see Section 6.1, Steps 1-5, 7) and adjust cathode assembly position (see Section 6.6, Step 1-3, 6-9).

- Take syringe (see "What's included") and fill with water/alcohol mixture (50% water and 50% ethyl alcohol)

- Open the filling neck cap.

- Insert the syringe into the filling neck hole while pressing the piston, fill until the torch

starts to drip the water-ethanol mixture from the nozzle. (see Figure)

- After filling, close the filling neck cap tightly and wipe torch body dry.

- Place the torch on the torch holder.

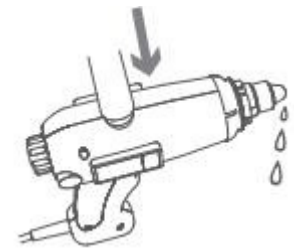

Caution!

- Fill torch immediately prior to operations.

- While refueling, hold the torch with filling hole up and keep the nozzle level higher than

the filling hole

- Starting unfilled torch result damage.

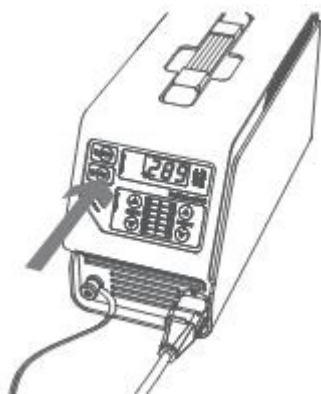

5.5 Torch Start

- Press step-by-step the left 6 or 5 buttons and select position 4 of MODE I current indicator.

- Make certain that power supply "OFF" LED is illuminated.

- Depress and release "ON" button on power supply. Make certain that "ON" LED is on (voltage reading will jump briefly to 200-350 V) (see figure).

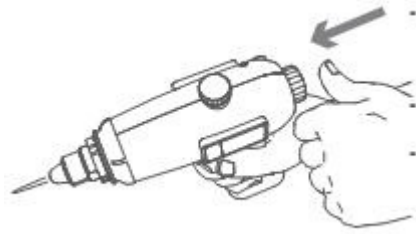

- Within 5 seconds after pressing "ON" button, fully depress start button (when cathode comes into contact with nozzle, the voltage will drop to 0 - 5 V), and release it slowly (voltage in initialized arc is between 20 and 80 V).

- Several seconds later a jet is supposed to appear from torch nozzle, while voltage will

increase to 80 -160 V.

- Set operating voltage to 160-170 V by turning start button clockwise.

Caution!

- If arc fails to form (display reading remains at 200 - 350 V), press start button again

within 5 seconds.

- If you fail to press the start button within the specified time, display reading will fall to

000 V and "OFF" LED will illuminate. If that were to happen, repeat start procedure (press "

ON" button and press start button).

- If a jet fails to form within 8 to 10 seconds or an arc cannot be started, deactivate torch

as specified in Sections 5.8, 5.10, identify and troubleshoot failure (see Section 7).

It is prohibited:

- to look inside nozzle to check for jet. It is dangerous!

5.6 Welding Procedure (2 Modes)

5.6.1 MODE I Welding

Welding in this mode is similar to gas welding.

Set appropriate MODE I current value as required based on metal thickness and recommendations

set forth in the Process Attachment (Section 8).

Prior to every indicator setting change by one step, verify that voltage display reading is

between 140 and 180 V. To increase voltage, turn start button clockwise, to reduce, turn start

button counterclockwise.

Caution!

- Before using the cutting torch for welding evaporate water performing Sections 5.2-5.5,

5.6.1. Set the current for MODE I to 6 (if using 110V, set to 4), set the torch on the torch

holder (see 'What's Included') and wait for the torch to automatically shut off.

5.6.2 MODE II Welding

Welding in this mode is similar to argon arc welding.

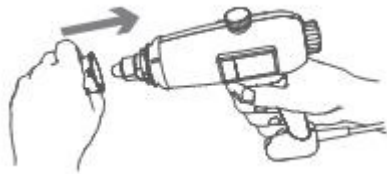

- Attach protective tip to torch (see Figure) and turn it until locked

- Connect MODE II wire with clamp to workpiece being welded (see Figure)

- Fill and start torch as described in Sections 5.4, 5.5.

- Set MODE I current indicator to positions 1 or 2 (see Section 7.4) in a step-by-step manner

- Activate MODE II by pressing right 5 button and set MODE II current indicator to positions 1 - 6 as per Process Attachment.

- Put on welder's mask (light shade of 5.5 DIN).

- Place nozzle with fired jet 1.5 to 2.0 mm (0,06-0,08 inches) from workpiece being welded.

- Make certain that the electric arc has jumped to the workpiece (do not allow nozzle contact with the workpiece).

- Maintain constant distance between nozzle and workpiece.

- Hold torch at about 70° to workpiece surface (see Figure).

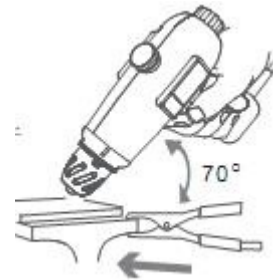

More detail on welding processes for various metals is provided in the Process Attachment

(Section 8).

It is prohibited:

- to utilize filler wire without a Filler Holder or welder's gloves.

- to operate in direct arc mode without welders mask (light shade of 5.5 DIN) and gloves.

Caution!

When operating in MODE I or MODE II

- If the jet should become extinguished inadvertently, fully press and immediately but slowly

release the torch start button within 5 seconds as for a nominal start to re-establish jet.

- When torch runs out of water-ethanol mixture, jet becomes elongated (or extinguished), and

voltage reading drops. If this were to happen, shut torch down manually before it shuts down automatically from overheating.

- If torch runs dry, it shuts down automatically, and OVERHEAT LED of power supply is

illuminated. To proceed with operations, perform operations per Section 5.10 and restart torch.

- Remove any molten splatter accumulated on nozzle by touching nozzle lightly with file or metal brush.

- Do not leave operating torch unattended.

Caution!

- Do not allow unprotected areas of your body to come into contact with hot torch surfaces.

- When operating in MODE II do not allow conductive items to come into contact with nozzle or cap unless secured in filler holder.

- Do not remove filling neck cap while torch is operational.

5.7 Soldering, Brazing, and Braze Welding Procedures

Soldering, brazing, and braze welding are normally performed using MODE I (see Section 5.6.1).

More detail on soldering, brazing, and braze welding of various materials is given in the

Process Attachment section (Section 8).

5.8 Torch Shutdown

- Press "OFF" button on power supply (see Figure).

- Make certain that "OFF" LED on power supply is illuminated.

- Cool torch down by dipping nozzle in 3 - 5 cm (1-2 inches) of WATER for several seconds until sizzling sound stops but no longer. Otherwise, torch will automatically fill with water rather than water/ethanol mixture, and most welding processes will become unavailable.

- If torch would fill with water, then evaporate it (see "Caution!" note at the bottom of page 25)



It is prohibited:

- to disconnect the torch cable connector with torch operational and/or "ON" LED illuminated.

This results in connector burnout



Caution!

If you want to shut torch off in case of emergency, press and hold start button 6-8 seconds.

Caution!

- Shut down and cool torch if nozzle turns red or jet turns green for a long time (see Sections 7.11, 7.12).

5.9 Refilling Torch

To refill torch with water/ethanol mixture, perform the steps described in Section 5.8 and 5.2. Automatic torch refilling(Section 4.8.2) with water/ethanol mixture is not possible.

Caution!

- Cool in WATER ONLY. Cooling in water/ethanol mixture could cause a fire.

5.10 After Operation

- Press "OFF" button on power supply.
- Be sure that "OFF" LED is illuminated.
- Disconnect torch cable connector from power supply outlet connector (to select cutting mode proceed to Section 4.2).
- Disconnect filler holder from power supply.
- Disconnect power supply power cable from wall receptacle.
- Disconnect MODE II wire with clamp from power supply

System Maintenance

6. System Maintenance. Torch Assembly and Disassembly.

Perform system maintenance in a timely manner.

Power supply maintenance requires blowing of vents and fan screens on a regular basis.

Torch maintenance requires regular inspections, timely cleaning of torch components, and replacement as necessary.

It is prohibited!

- to perform maintenance with torch operational and with torch cable connected to power supply.

6.1 Torch Disassembly

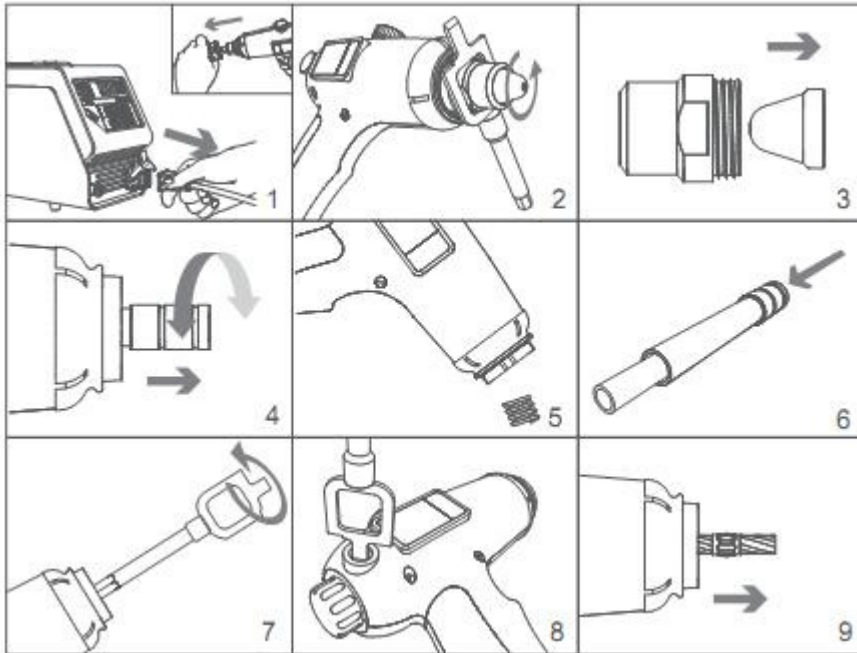

1. Make certain torch is not operational and that "OFF" LED is illuminated, then detach torch from the power supply. Remove protective tip.
2. Take combination wrench (see "What's included") and loosen torch cap by rotating counterclockwise.
3. Remove cap and remove nozzle from cap.
4. Pull on protruding section of evaporator to remove evaporator from housing by rotating slightly from side to side.
5. Tilt torch to allow the spring to slide out (be careful not to lose spring).
6. Take plunger (see "What's included"). Remove quartz tube from evaporator by pressing with plunger tapered end on front edge of quartz tube from the side of the evaporator wider end.
7. Remove cathode from cathode holder by turning it counterclockwise with combination wrench.
8. Take off protective cap. Use screw driver to loosen cathode holder retaining screw by turning it 2-3 turns counterclockwise. If the screw is inaccessible and shifted forward, rotate start button clockwise.
9. Remove cathode holder from torch by grabbing cathode with your fingers or pliers. Keep torch and cathode holder aligned. Do not rotate cathode holder.

6.2 Torch Disassembly Tips and Techniques

- A) Nozzle is jammed in cap: press it out with plunger.
- B) Nozzle is "stuck" to evaporator: remove evaporator with nozzle, place cap over nozzle such that cap and nozzle back edges align, and "break" nozzle off using cap without exerting force.
- C) Cathode is heavily melted: remove evaporator and cathode holder from torch (after Section 6.1 Step 8).
- D) Cathode is melted to cathode holder: secure cathode holder in a vise and loosen cathode with combination wrench or pliers.

Caution!

- Do not use force or impact on copper components.

6.3 Evaporator Assembly Status Check

If you use water with high mineral levels, mineral deposits will gradually form on the evaporator. In this case, moisten the evaporator in water, and use a scraper or fine- sand paper or metal brush to remove any mineral deposits. Using distilled water will help prevent mineral deposits from forming on the evaporator. If required, clean quartz tube of copper residue and soot by placing in acetic acid (or ferric chloride) for several hours or by grinding with fine sandpaper under exceptional circumstances. If copper residue cannot be removed, install quartz tube to position copper-contaminated section in tapered section of evaporator (Section 6.6 Step 4) or replace with new one. In the event of chipping or cracking, replace tube. Verify there are 2 radial thrust springs inside evaporator. If springs are damaged, replace springs. Make certain that cathode assembly is loose enough inside quartz tube to be moved without much force.

6.4 Cathode Assembly (Cathode Holder with Cathode) Status Check

Inspect tip of cathode. In the event that there is a crater of over 0.3 mm (0.01 inch) in cathode central insert (and signs of copper pitting), remove crater with file rounding cathode tip into a cone shape.

Measure cathode length. Replace cathode if less than 15 mm (0.6 inch) in length (not including threaded section).

Apply graphite lubricant to cathode thread (to avoid cathode fusion).

Use cloth to remove excess graphite lubricant.

Thread cathode into cathode holder and tighten with combination wrench to achieve reliable connection but without significant force (see figure). Verify cathode is aligned with cathode holder by rolling cathode assembly around on a level surface. Align if required.



Caution!

- Cathode can be replaced without removing cathode assembly from torch.
- After filing always check cathode length!

6.5 Nozzle Status Check

Replace nozzle with a new one if nozzle bore diameter increases to 1.3 mm (0.05 inch) for cutting and to 2.5 mm (0.1 inch) for welding. Used cutting nozzles may be re-used for welding by opening the nozzle bore with a 2.2-mm (0.085-inch) drill bit and countersink with a 3.5-mm (0.14-inch) drill bit.

6.6 Torch Assembly

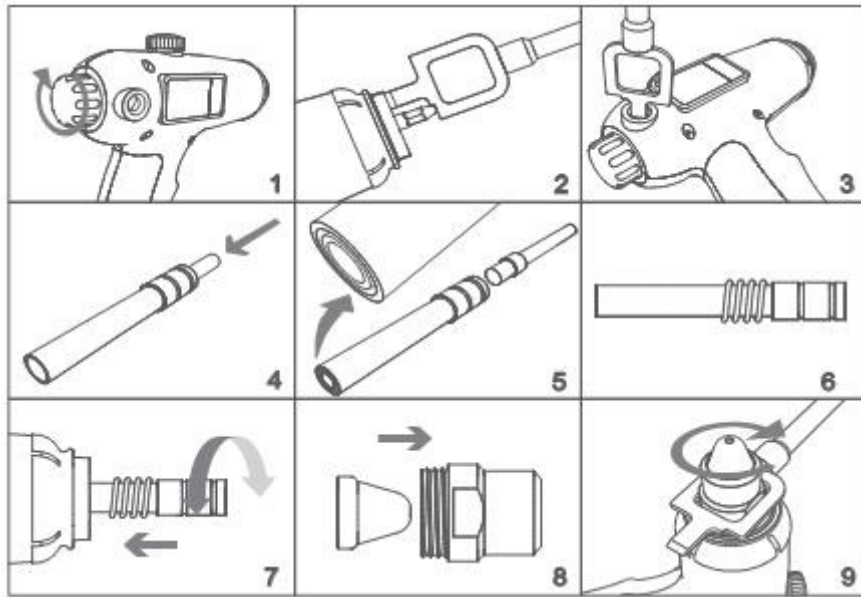

1. Rotate start button clockwise to hard stop.
2. Take cathode assembly and fully insert into torch. Rotate cathode assembly around such that the flat on its tapered end slide into fastener fitting (flat is secure if cathode assembly does not turn). Using the combination wrench, insert the cathode assembly into the torch until the cathode sticks out of the body 19 mm (0.75 inch) for welding (red mark on wrench) and 17 mm (0.65 inch) for cutting (green mark).
3. Tighten cathode holder retaining screw by turning it clockwise. Verify cathode assembly is secure by pulling on it without screw in the outward direction. Install protective cap over screw hole.
4. Gently slide quartz tube into thicker end of evaporator.
5. Place tapered end of evaporator on a level wooden surface. Using thicker end of plunger, finalize quartz tube installation such that tube end aligns with evaporator end.
6. Install spring into evaporator.
7. Rotating evaporator slightly from side to side, slide it over cathode holder keeping it in alignment.
8. Select appropriate nozzle and insert into cap.
9. Place cap and nozzle over protruding section of evaporator making sure there is no nozzle misalignment. Tighten cap clockwise using combination wrench.

It is prohibited:

- to install quartz tube over thinner end of evaporator.

Questions and Answers

7. Questions and Answers Troubleshooting Techniques

Caution!

Do not attempt repairs if the failure is not described in this section. Instead, contact an authorized dealer for assistance

7.1 Current indicator fails to be set in position 5-6.
Supply network voltage is 110V. Use a 200-240V power supply.

7.2. Voltage display and "OFF" LED failed to illuminate following connection to power?
Unplug power supply. Make certain that the wall receptacle provides power with a voltage of between 100 and 253 V. Check fuse of power supply. Replace if required (please contact your authorized dealer with any questions about slow blow fuse with a current rating of 25 A). If failure persists, call the authorized dealer.

7.3. Plasma jet fails to form 5 - 8 seconds after start button is pressed with display showing 50 - 80 V.

A) Nozzle Contaminated.

* Clean nozzle using drill bit (see 'Whats included').

B) Quartz tube cracked.

* Replace quartz tube with one from spares.

7.4. How can current value be changed?

Every time the MODE I control setting is changed by one position, make certain that the voltage display value is between 140 and 180 V. To increase voltage turn the start button clockwise, to reduce - counterclockwise.

7.5. Torch unstable - spattering

This is normal when using a new torch or after long storage. If it occurs to a torch that has been used already, it is necessary to bring the torch to the authorized dealer where it will be repaired or replaced.

7.6. ON indicator turns itself off after startup?

Power supply or torch failed. If power supply works with another torch, torch has failed. If the failure manifests itself with both torches, it is likely that power supply has failed. Bring power supply and torches to the authorized dealer for repair or replacement.

7.7. System not cutting black steel with a thickness in excess of 3 mm (0,12 inch)

Torch is not adjusted.

A) Filler neck cap or torch cap is loose

* B) Cathode assembly incorrectly recessed (Section 6.6, Figure 2).

* C) Cathode assembly misaligned (Section 6.4).

* D) Check diameter of nozzle orifice (Section 6.5).

7.8. Stainless steel not welding

Use an ethyl alcohol concentration of 55% to 60% and appropriate filler wire (see Process Attachment) . For thickness of under 2.5 mm (0,1 inch) use brazing (brass or silver-based solder).

7.9. Process fluid leak from under the cap

Cap not tight enough - tighten cap.

7.10. Process fluid leak from under the torch filler neck cap

Filler neck cap not tight enough - tighten cap.

7.11. Plasma jet is green in color.

A) Burnout of central hafnium insert at cathode tip (crater depth exceeds 0.3 mm, i.e. 0,01 inch).

* File cathode down until crater disappears (Section 6.4).

B) Cathode and nozzle misaligned.

* Remove cathode assembly from torch and align (Section 6.4).

7.12. Nozzle turns red during operation.

A) Nozzle contaminated.

* Clean nozzle with drill bit (see "What's included").

B) Cap loose.

Tighten cap using greater torque.

C) Presence of a foreign particle such as a sand grain between nozzle and evaporator.

* Clean contacting surfaces of nozzle and evaporator.

D) Nicks on contacting surfaces of nozzle and evaporator.

* Grind contact surfaces with fine sand paper on a smooth surface.

E) Spring not installed on evaporator.

* Remove evaporator and install spring (Section 6).

7.13. Difficulty starting torch

Perform torch maintenance (Section 6).

7.14. Service life of consumables? Where can consumables be purchased?

Cathode life is 20-40 hours (depends on operating mode and timely maintenance) while that of nozzles is several times longer.

All consumables are available from an authorized dealer

.

7.15. Voltage indicator shows messages not described in manual.

If "ON" button is depressed repeatedly, the indicator will display digital engineering data describing power supply status. These data have no impact on power supply operation. This is indicated by a decimal point found in the digital data.

If this should be the case, continue pressing the "ON" button of the front panel of the power supply until there are no points on the display.

7.16. Repair, Service, and Support

Repair and maintenance are performed by authorized dealers.

Process Attachment

8. Process Attachment

1. General Recommendations for New Welders.
2. Low-Alloyed Steel Welding Technology.
3. Aluminum Alloy Welding Technology.
4. Stainless Steel Welding and Brazing Technology.
5. Cast Iron Welding Technology.
6. Copper and Copper-Base Metal Welding and Brazing Technology.
7. Dissimilar Metal Welding, Brazing, and Braze Welding Technology.
8. Metal and Non-Metal Cutting Technology.

The Multiplaz-3500 system is used to produce permanent joints of various metals by welding, brazing, braze welding, and soldering. Low-alloyed and stainless steel, aluminum alloys, copper, copper-base metals, and cast iron can be welded. In most cases, permanent joints of both aluminum alloys and stainless steel can be produced without using shielding gases. The system produces quality welds in any position.

Caution!

To operate in inaccessible locations (such as, when welding pipes 15 mm, i.e. 0.6 inch, from a wall), use a nozzle with a "slanted" orifice (see Spare Parts Kit).

Use special lubricant (available from authorized dealers) to reduce metal splatter accumulation on nozzle exterior.

1. General Recommendations for New Welders

Place "burning" torch at metal joint and cause workpiece edges to melt simultaneously to form a common molten metal bath. Move torch along joint at a rate sufficient to keep the metal molten while holding the nozzle a constant distance away from the workpiece.

Heat (melting) is controlled by the distance between nozzle and workpiece.

For MODE I welding, the greater the clearance from the workpiece, the lower plume temperature.

For MODE II welding, the greater the clearance from the workpiece, the longer and the more intense the arc and the more intense the heating of the metal.

When the MODE I indicator is in positions 1 and 2 special emphasis must be placed on cathode and inner nozzle surface cleanliness (see Sections 6.4, 6.5). As the nozzle wears out (hole diameter increases), the torch may become unstable when the MODE I indicator is in position 1. If that is the case, move MODE I indicator to position 2.

Use filler wire with diameter 1-4 mm (0.04-0.16 inches) depending on metal thickness.

For soldering, heat the workpieces being joined to brazing temperature, which is some 10% higher than filler melting point but lower than base metal melting point. On contact with hot workpieces, filler melts puddle workpiece surfaces and filling the gap between them.

For brazing, heat the workpiece with the higher melting point to a temperature about 10% higher than the melting point of the other workpiece. The molten metal of the second workpiece serves as filler for this joint.

For braze welding, the workpieces being joined are set up the same way as they would be for welding while the gap is filled with molten braze.

2. Low-Alloyed Steel Welding Technology

The system welds low-alloyed steel with thicknesses of 0.3 mm (0,01 inch) and up without restriction to thickness.

Welding modes are shown in Table 1.

Table 1. Low-Alloyed Steel Welding

Material	Workpiece Geometry	Primary Dimension, mm (inch)	Type of Process	Filler	Filler Diameter, mm	Flux	MODE I / MODE II	Control Setting, V
Steel + Steel	Pipe + Pipe	Ø 57 x 4 Ø 57 x 4	Welding (50%)*		3	None	1 / 4 2 / 4	160 - 190 150 - 170
Steel + Steel	Strip + Strip	100 x 120 x 6 100 x 120 x 6	Welding (50%)		3	None	1 / 4 2 / 4	160 - 190 150 - 170
Steel + Steel	Pipe + Pipe	Ø 57 x 4 Ø 57 x 4	Welding (50%)		3	None	1 / 4 2 / 4	160 - 190 150 - 170
Steel + Steel	Plate + Plate	δ = 2 δ = 2	Welding (50%)		1,6	None	1 / 1 2 / 2 3 / 3	160 - 180 160 - 170 150 - 170
Steel + Steel	Plate + Plate	δ = 8 δ = 8	Welding (50%)		3	None	2 / 4	150 - 170

Thin steels like with a thickness of around 0.4 mm (0.015 inch) are welded in the following configuration: MODE I indicator is in position 1, MODE II is off, voltage is set to 135-145 V. Filler wire: 0.8-1 mm diameter (0,03-0,04 inches). A nozzle with a hole of diameter 1.8 mm (0.07 inch) may be used to improve heat flux concentration in welding area (a simple tool can be used to counterdrill the nozzle of diameter 1.1 mm (0.043 inch) using the appropriate drill from spares). Welding is best performed on a copper or an aluminum backer plate to avoid steel overheating or burn through.

3. Aluminum Alloy Welding Technology

The technology for welding most common aluminum alloys is practically the same. Clean welding area; degrease as necessary. Heat the tip of filler wire and dip in flux (for flux adhesion). Heat the weld area until edge melting begins (if workpiece is thick, use additional heat sources). Bring the filler to the molten edges. This will cause the flux to melt and cover welding area uniformly. To form a welding bath, make filler and molten edges of workpiece to flow together. Set filler along joint of workpieces. Watch the flux to be on filler. Weld using MODE I (see Table 2) . Hold torch at 60-70 degrees to surface. Carefully select distance between torch nozzle and weld area as well as welding rate to avoid sagging. Remove excess flux after welding.

Welding modes are shown in Table 2.

Table 2. Aluminum Alloy Welding

Material	Workpiece Geometry	Primary Dimension, mm	Type of Process	Filler	Filler Diameter, mm	Flux	MODE I / MODE II	Control Setting, V
Aluminum Alloy + Aluminum Alloy	Window Frame Segment	$\delta = 2$	Welding (50%)*		2		1 / off 2 / off	160 140 - 160
Aluminum Alloy + Aluminum Alloy	Window Frame Segment	$\delta = 4$	Welding (50%)		4		2 / off 3 / off	160 - 180 140 - 160
Aluminum Alloy + Aluminum Alloy	Plate + Plate	$\delta = 2$	Welding (50%)		2		1 / off 2 / off	160 140 - 160

Table 2. Aluminum Alloy Welding (Continued)

Material	Workpiece Geometry	Primary Dimension, mm	Type of Process	Filler	Filler Diameter, mm	Flux	MODE I / MODE II	Control Setting, V
Aluminum Alloy + Aluminum Alloy	Busbar + Busbar	$\delta = 4$	Welding (50%)		3		2 / off 3 / off	160 - 180 140 - 160
Aluminum Alloy + Aluminum Alloy	Frying Pan + Handle	$\delta = 5$	Welding (50%)		4		2 / off 3 / off	160 - 180 140 - 160
Aluminum Alloy + Aluminum Alloy	Plate + Plate	$\delta = 5$	Welding (50%)		5		4 / off	140 - 160
Aluminum Alloy + Aluminum Alloy	Square Angle + L-Angle	20 x 20 x 2 15 x 20 x 2	Welding (50%)		1.6		1 / off	140 - 160
Aluminum Alloy + Aluminum Alloy	Strip + Strip	$\delta = 4$	Welding (50%)		4		2 / off 3 / off	160 - 180 140 - 160
Aluminum Alloy	Tubes	$\varnothing 22 \times 1.5$	Welding (50%)		2.4		1 / off	140 - 160
Aluminum Alloy + Aluminum Alloy	Sector + Plate	$\delta = 0.5$ $\delta = 1$	Brazing (50%) (T-joint)		2		1 / off	160 - 170

* Ethanol concentration in water/alcohol mixture is shown in parentheses.

4. Stainless Steel Welding and Braze Welding Technology

Service torch with water/alcohol mixture and select appropriate mode (see Table 3). Bevel weld areas and set required clearances between workpieces. Do not interrupt welding until end of joint. Variety of stainless steels requires to select carefully the fillers and fluxes.

Braze welding is effective for stainless steel with a thickness of under 2.0 mm (0,08 inch). Clean work area with metal brush and heat uniformly. Apply flux for brazing with silver filler. Melt flux to achieve uniform brazing area coverage. At the same time, heat edges of pieces being joined to braze melting temperature. Braze melts from contact with hot metal, Welding and braze welding modes are shown in Table 3.

Table 3. Stainless Steel Welding and Braze Welding.

Material	Workpiece Geometry	Primary Dimension, mm	Type of Process	Filler	Filler Diameter, mm	Flux	MODE I / MODE II	Control Setting, V
Stainless Steel + Stainless Steel	Tube + Tube	Ø 24 x 6	Welding (60%)*		3	None	1 / 4 2 / 4	160 - 190 150 - 170
Stainless Steel + Stainless Steel	Tube + Tube	Ø 8 x 1	Braze welding (50%)		1.0		1 / off 2 / off	160 - 190 150 - 170
Stainless Steel + Stainless Steel	Tube + Tube	δ = 1	Braze welding (50%)		1.0		1 / off 2 / off	160 - 190 150 - 170
Stainless Steel + Stainless Steel	Tube + Tube	Ø 20 x 2	Welding (60%)		3	None	1 / 4 2 / 4	160 - 190 150 - 170

Table 3. Stainless Steel Welding and Braze Welding (continued)

Material	Workpiece Shape	Primary Dimension, mm	Type of Process	Filler	Filler Diameter, mm	Flux	MODE I / MODE II	Control Setting, V
Stainless Steel + Steel	Plate + Plate	δ = 4.5	Butt Welding (60%)		2.5	None	1 / 4 2 / 4	160 - 190 150 - 170
Stainless Steel + Steel	Plate + Plate	δ = 4.5	Lap Welding (60%)		2.5	None	1 / 4 2 / 4	160 - 190 150 - 170

* Ethanol concentration in water/alcohol mixture is shown in parentheses.

5. Cast Iron Welding Technology

Cast iron welding for thicknesses up to 3 mm (0,12 inch) is performed in MODE II. Steel wire and pig iron are used as fillers. Preheating is required before cast iron welding. Do not remove torch immediately after weld is finished but raise it gradually rocking it slowly back and forth along weldment.

Cast iron welding modes are shown in Table 4.

Table 4. Cast Iron Welding.

Material	Workpiece Geometry	Primary Dimension, mm	Type of Process	Filler	Filler Diameter, mm	Flux	MODE I / MODE II	Control Setting, V
Gray Iron	Heating Pipe Run	δ = 4	Welding (50%)		3	None	1 / 4 2 / 4	160 - 190 150 - 170

* Ethanol concentration in water/alcohol mixture is shown in parentheses.

6. Copper and Copper-Base Metal (Copper, Brass, Bronze, etc.) Welding and Braze welding Technology

Copper fillers, copper-zinc fillers, copper-phosphorous fillers, and specialized fluxes are used in the course of welding and braze welding.

It is best to use simple water rather than a water/alcohol mixture and preliminary heating of workpiece for braze welding of copper.

Welding and braze welding modes are shown in Table 5.

Table 5. Copper and Copper-Base Metal Welding and Braze Welding

Material	Workpiece Geometry	Primary Dimension, mm	Type of Process	Filler or Braze	Filler Diameter, mm	Flux	MODE I / MODE II	Control Setting, V
Brass + Brass	Plate + Plate	$\delta = 1.2$	Welding (50%)*	Brass Wire	2.5	None	1 / off 2 / off	160 - 190 150 - 170
Brass + Brass	Plate + Plate	$\delta = 1.2$	Welding (50%)	Brass Wire	2.5		1 / off 2 / off	160 - 190 150 - 170
Copper + Copper	Plate + Plate	$\delta = 2.5$	Braze welding (50%)		3	None	1 / off 2 / off	160 - 190 150 - 170
Copper + Copper	Busbar + Busbar	$\delta = 5$	Butt Welding**	Copper Wire	2	None	2 / 4 3 / 4	160 - 180 150 - 170
Copper + Copper	Plate + Plate	$\delta = 6$	Butt Welding**	Copper Wire	2	None	2 / 4 3 / 4	160 - 180 150 - 170
Copper + Copper	Plate + Plate	$\delta = 4.5$	Butt Welding**	Copper Wire	2	None	2 / 4 3 / 4	160 - 180 150 - 170

* Ethanol concentration in water/alcohol mixture is shown in parentheses.

** This process uses simple water.

7. Dissimilar Metal Welding, Brazing, and Braze Welding Techniques.

Techniques for welding, brazing, and braze welding dissimilar metals are based on traditional methodologies.

The relevant modes are shown in Table 6.

Table 6. Welding, Brazing, and Braze Welding of Dissimilar Metals.

Material	Workpiece Geometry	Primary Dimension, mm	Type of Process	Filler or Braze	Diameter of filler, mm	Flux	MODE I / MODE II	Setting, V
Steel + Copper	Plate + Plate	$\delta = 0.8$ $\delta = 0.5$	Braze Welding (50%)*	Copper-phosphorous Filler	2		1 / off	160 - 190
Steel + Copper	Wire + Wire	$\delta = 0.5$	Braze Welding (50%)		2		1 / off	160 - 190
Steel + Stainless Steel	Plate + Plate	$\delta = 4.5$ $\delta = 4.5$	Butt and Lap Welds (60%)		2.5	None	1 / 4 2 / 4	160 - 190 150 - 170
Aluminum Alloy + Stainless Steel	Tube + Tube	$\varnothing 10 \times 1$ $\varnothing 8 \times 1$	Brazing (50%)		2.4		1 / off	160 - 190
Aluminum Alloy + Stainless Steel	Tube + Tube	$\varnothing 10 \times 1$ $\varnothing 8 \times 1$	Brazing (50%)		2.4		1 / off	160 - 190
Aluminum Alloy + Copper	Tube + Tube	$\varnothing 12 \times 1$ $\varnothing 10 \times 1$	Brazing (50%)		2.4		1 / off	160 - 190
Copper + Steel	Tube + Tube	$\varnothing 10 \times 1$ $\varnothing 34 \times 2$	Braze Welding (50%)		2.5		1 / off	160 - 190
Cast Iron + Stainless Steel + Copper	Segment Tube Tube	$\delta = 3 - 4$ $\varnothing 10 \times 1$ $\varnothing 10 \times 1$	Braze Welding (50%)		b = 4 - 5		3 / выкл.	150 - 160

* Ethanol concentration in water/alcohol mixture is shown in parentheses.

Table 6. Welding, Brazing, and Braze Welding of Dissimilar Metals (continued).

Material	Workpiece Geometry	Primary Dimension, mm	Type of Process	Filler or Braze	Filler Diameter, mm	Flux	MODE I / MODE II	Control Setting, V
Cast Iron + Copper	Segment + Tube	$\delta = 3 - 4$ $\varnothing 10 \times 1$	Welding (50%)*	Copper Wire	2	None	1 / off 2 / off	160 - 190 150 - 170

* Ethanol concentration in water/alcohol mixture is shown in parentheses.

Example 1. Braze welding of Copper for Electrical Engineering Applications and Aluminum Alloy. Copper plate (thickness of 3 mm, i.e. 0.12 inch) is beveled at 45 degrees. This surface is subsequently treated with the copper-zinc braze with specialized flux. It is then treated using aluminum wire with flux for aluminum wire. Tinned copper is welded to aluminum using aluminum wire with flux for aluminum welding (MODE I - "4", U = 140 - 150 V).

Example 2. Braze welding of Aluminum Tubing diameter 10 mm x thickness 1 mm (0,3 x 0,04 inches) with Stainless Steel Tubing diameter 8 mm x thickness 1 mm (0,3 x 0,04 inches). Stainless steel tubing is roughened with a coarse file, coated in aluminum flux and treated with aluminum wire filler. This area is subsequently treated with flux for welding aluminum. Aluminum tubing is then brazed to stainless steel tubing using aluminum wire.

8. Metal and Non-Metal Cutting Techniques

Plasma jet high temperature and effluence rates support the cutting of practically any non-flammable material, including ferrous and non-ferrous metals, ceramic materials, concrete, stone. A cutting rate of 7 mm (0,3 inch) per second can be achieved for low-alloyed steels with thicknesses of up to 2 mm (0.08 inch), and up to 1 mm (0,04 inch) per second for thicknesses of 10 mm (0,4 inch).

Insulating materials are cut in MODE I.

To produce high-quality cuts in different metals:

- avoid transverse torch motion with respect to the cut,
- maintain a constant clearance of 1.5-2.0 mm (0.06-0.08 inches) between torch nozzle and metal being worked,
- select torch translation rate such that a spot of light is always visible on the backer plate under the cut and maintain this rate constant.
- control dross influx by leaning the torch slightly to the side.

Cutting quality may be improved by using different supports and compasses from "What's included" which may be installed onto torch using a clamp bracket (see "What's included").

- Install clamp bracket onto torch and secure with coupling screw.
- Install ball support into clamp bracket (see 'What's included') to make the clearance between torch nozzle and workpiece about 2 mm (0,08 inches) with nozzle upright and secure with screw on bracket.

Use compass from "What's included" instead of ball support to cut round holes.

When cutting, keep in mind that the unit's plasma jet is supposed to remove molten metal through the cut.

This requires cuts to be initiated at the workpiece edge. If this should prove impossible from the process standpoint, a hole must be drilled to be used for cut initiation. For thin sheet metal, "punch-through" cutting may be used where the initial hole is obtained by burning through the metal. When using "punch-through" cutting, protect the torch from backwash and sparks until a through hole is obtained. This is accomplished by holding the torch at less than 90 degrees to the workpiece surface at the start of the "punch-through" procedure. Please note, that it is not possible to achieve a high-quality cut using the "punch-through" technique.

To cut the steel sheets of thickness 0,5-1 mm (0.02-0.04 inches), it is sufficient to set MODE I to position 1-4 and set voltage to 190-210 V. Steel sheets of 1-3 mm (0,04-0,12 inches) may be cut using MODE I and setting the current indicator to position 6 and setting the voltage display to 210-230 V.

Thicker sheets should be cut using MODE II. Set the MODE I current indicator to position 6 and voltage to 210-220 V. Then activate MODE II.

Direct arc of MODE II appears automatically as the torch nozzle is brought 2-3 mm (0.08-0.12 inches) from the surface of the workpiece.

Select rate of torch translation along cut such that the arc stays on the workpiece material and molten metal is removed. If torch translation rate is too high, metal will not be cut, and if translation rate is too low or zero, direct arc may break because there is no metal in the cut.